



NSW1-205-8A

1 inch "Cougar" Extended Range Loudspeaker

- **Wide Frequency Range**
- **High Output**
- **Low Distortion**
- **Ultra Compact Design**
- **No Stray Magnetic Fields**



Nominal Diameter 1 inch (25 mm)
 Nominal Impedance (Z) 8 ohms
 Sensitivity, 1W/1m (E) 78 dB @ 1 kHz
 Power Capacity, RMS (Pe) 5 W
 Power Capacity, Peak 20 W
 Frequency Range (-10dB) 220 Hz - 20 kHz
 Minimum Impedance 7 ohms
 Voice Coil Diameter 20.5 mm
 Voice Coil Winding Length (h) 3 mm
 Voice Coil Number of Layers (n) 2
 Voice Coil Former Material Aluminum
 Voice Coil Wire Composition CCAW
 Magnetic Material Neodymium radial
 Stray Flux Shielding Inherent
 Magnetic Gap Depth (He) 6 mm
 Cone Material Titanium
 Surround Material Foam
 Polarity, Outward Motion Positive voltage on (+) terminal
 Net Weight 52.3 g
 Maximum Excursion 9 mm peak to peak

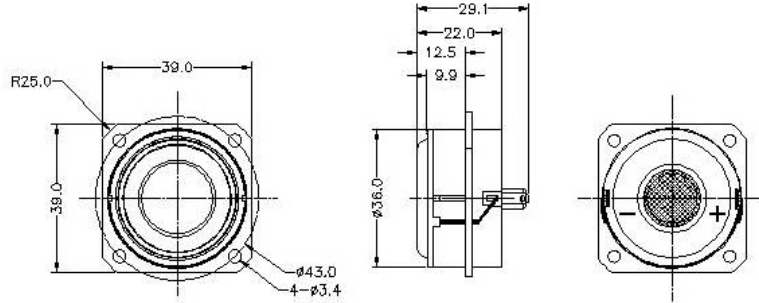

Thiele / Small Parameters

Resonant Frequency (Fo) - Fs 220 Hertz
 Voice Coil DC Resistance - Re 6.3 ohms
 Total Q - Qts 0.7
 Mechanical Q - Qms 2.1
 Electrical Q - Qes 1.1
 Equivalent Volume of Air - Vas 0.04 L
 Radiating Piston Area - Sd 5.31 cm²
 Xmax 4.5 mm peak to peak

Electrical / Mechanical Parameters

Flux Density x Length - BL 1.9 Tesla-meters
 Compliance - Cms 1155 μm/N
 Total Mass - Mms 0.5 grams

Frequency Response (1W, 1m)

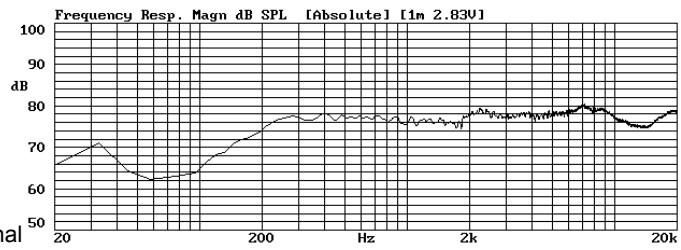

Impedance

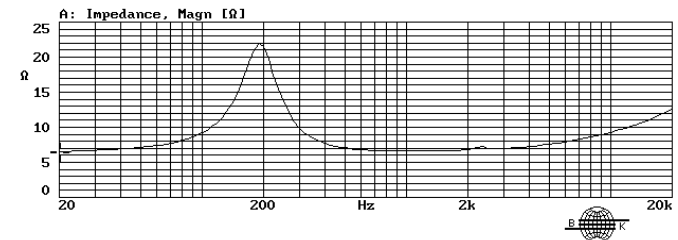

Distortion (1W,1m)

